



DOSATRON®

WATER POWERED DOSING TECHNOLOGY

ESQUEMATICAS

Dispensador de Líquido Dosatron **Modelo # D25RE1500 – 11 GPM / 42 LPM**

1:1500 - 1:500

4.3 - 85 PSI

Conexión ¾" NPT

Instalación Sugerida:

Instale un filtro de malla de 200/80 micrones antes del dosificador

Instale una válvula cheque después del dosificador para evitar la presión de vuelta.

Intervalo de Mantenimiento Sugerido:

Reemplace los sellos/empaques cada 12 meses

DOSATRON SALES & SERVICE - NORTH & CENTRAL AMERICA

Dosatron International, Inc.

Telefono : 727-443-5404 Servicio: (800) 523-8499

Fax: 727-447-0591

www.dosatronUSA.com

D25RE1500

11/03

11 GPM - 1:1500 - 1:500

4.3 - 85 psi

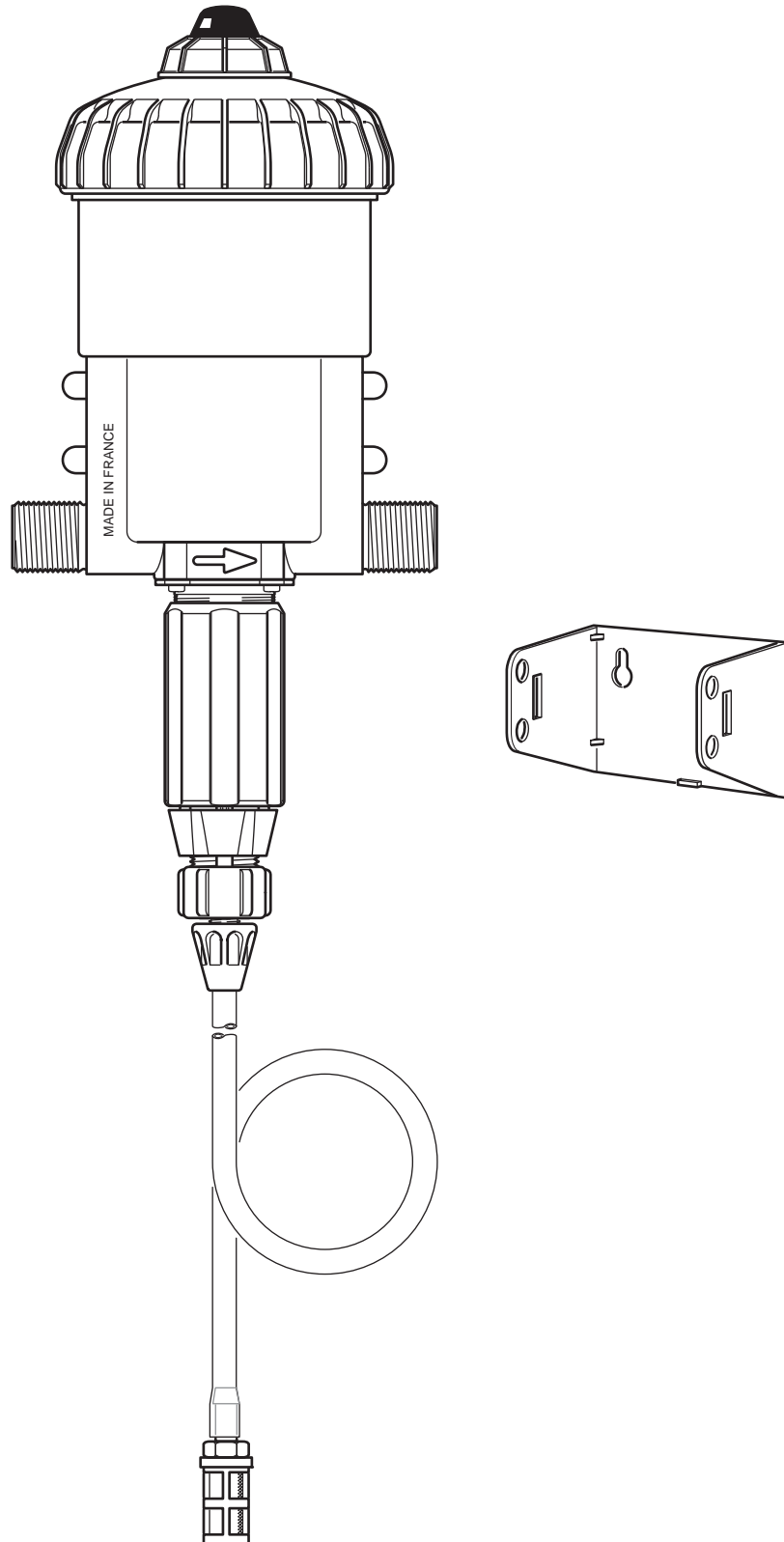

PJ118 - Injection Seal Kit

D25RE1500

11/03

11 GPM - 1:1500 - 1:500

4.3 - 85 psi

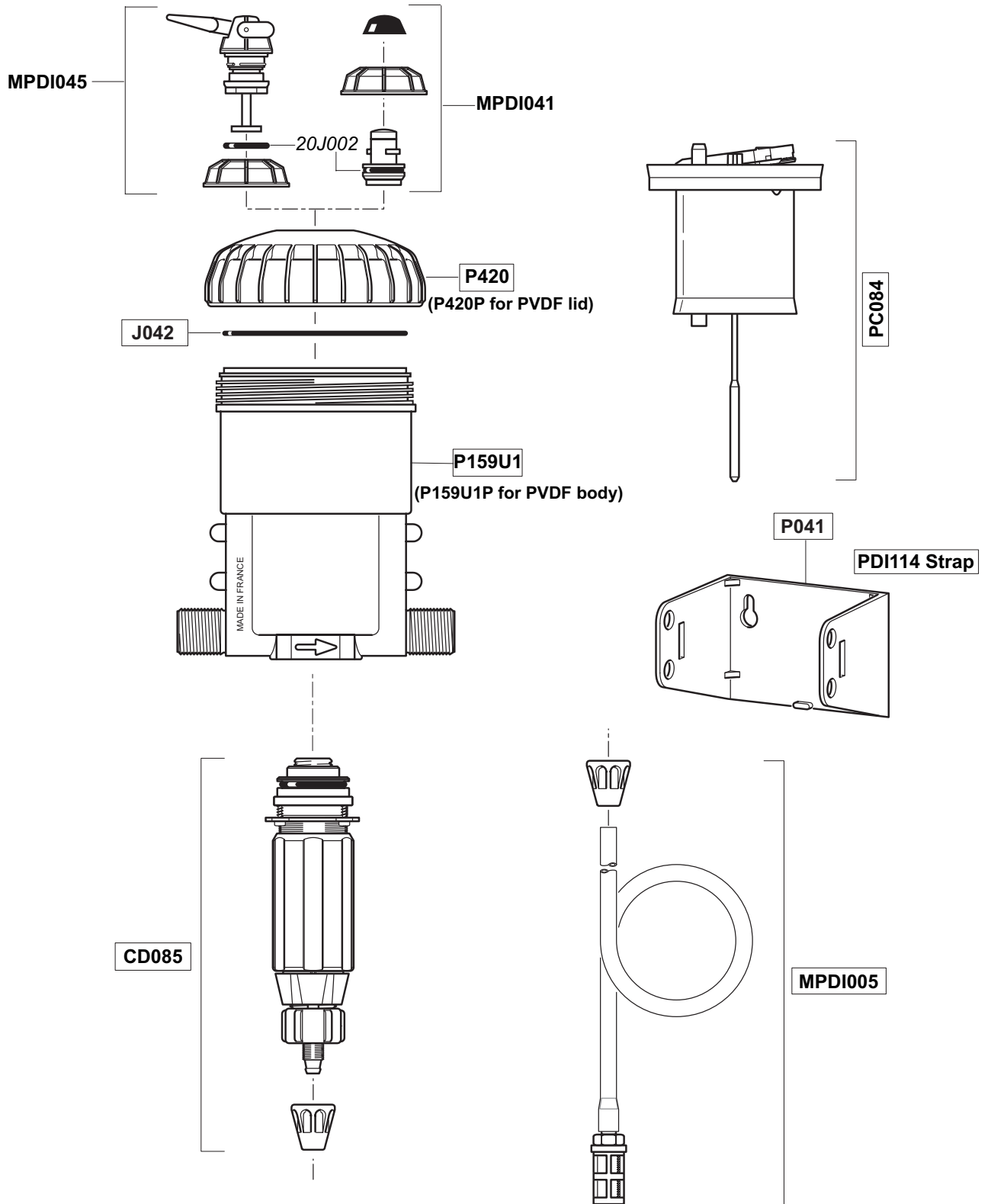

D25RE1500

11/03

11 GPM - 1:1500 - 1:500

4.3 - 85 psi

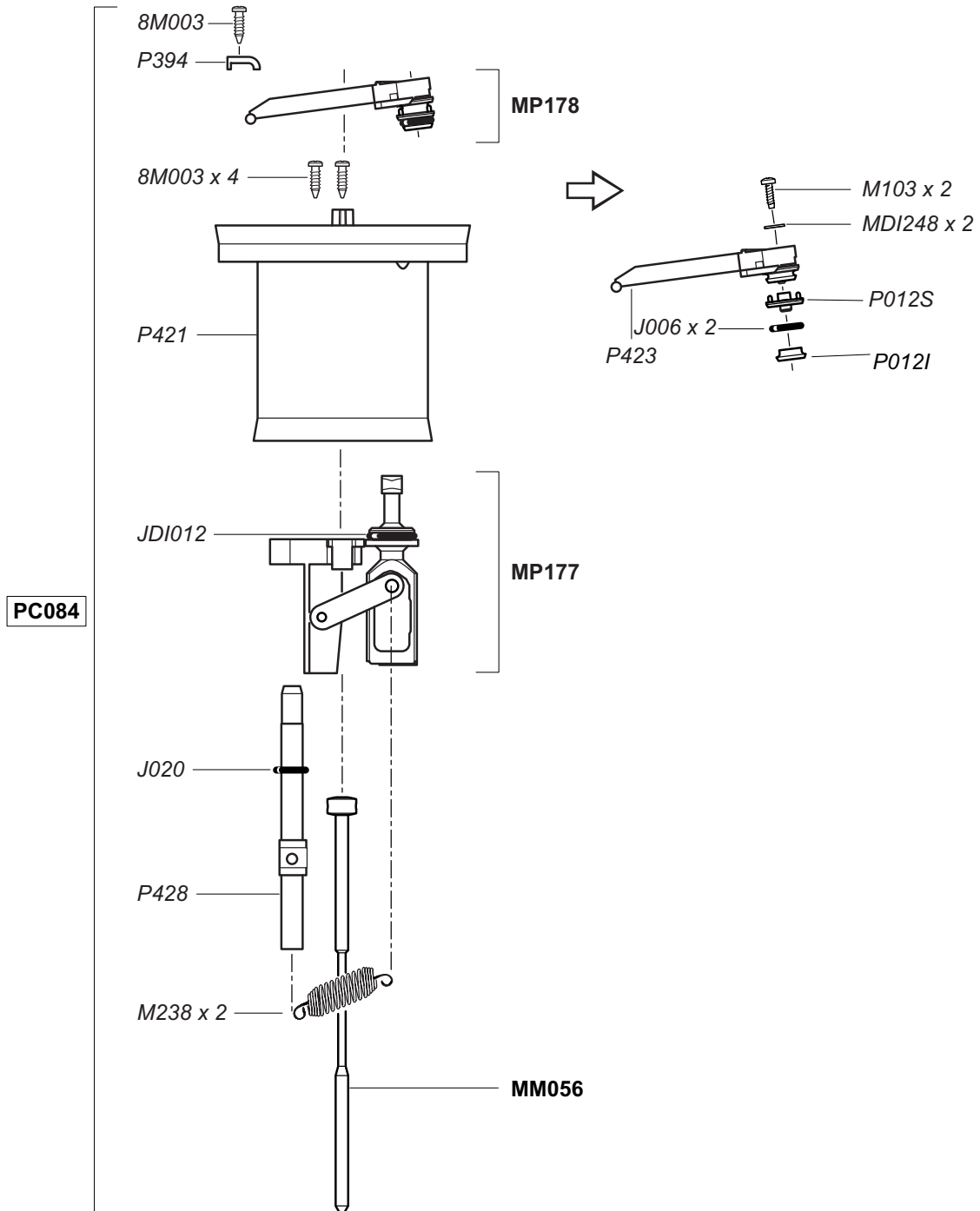

D25RE1500

11/03

11 GPM - 1:1500 - 1:500
4.3 - 85 psi

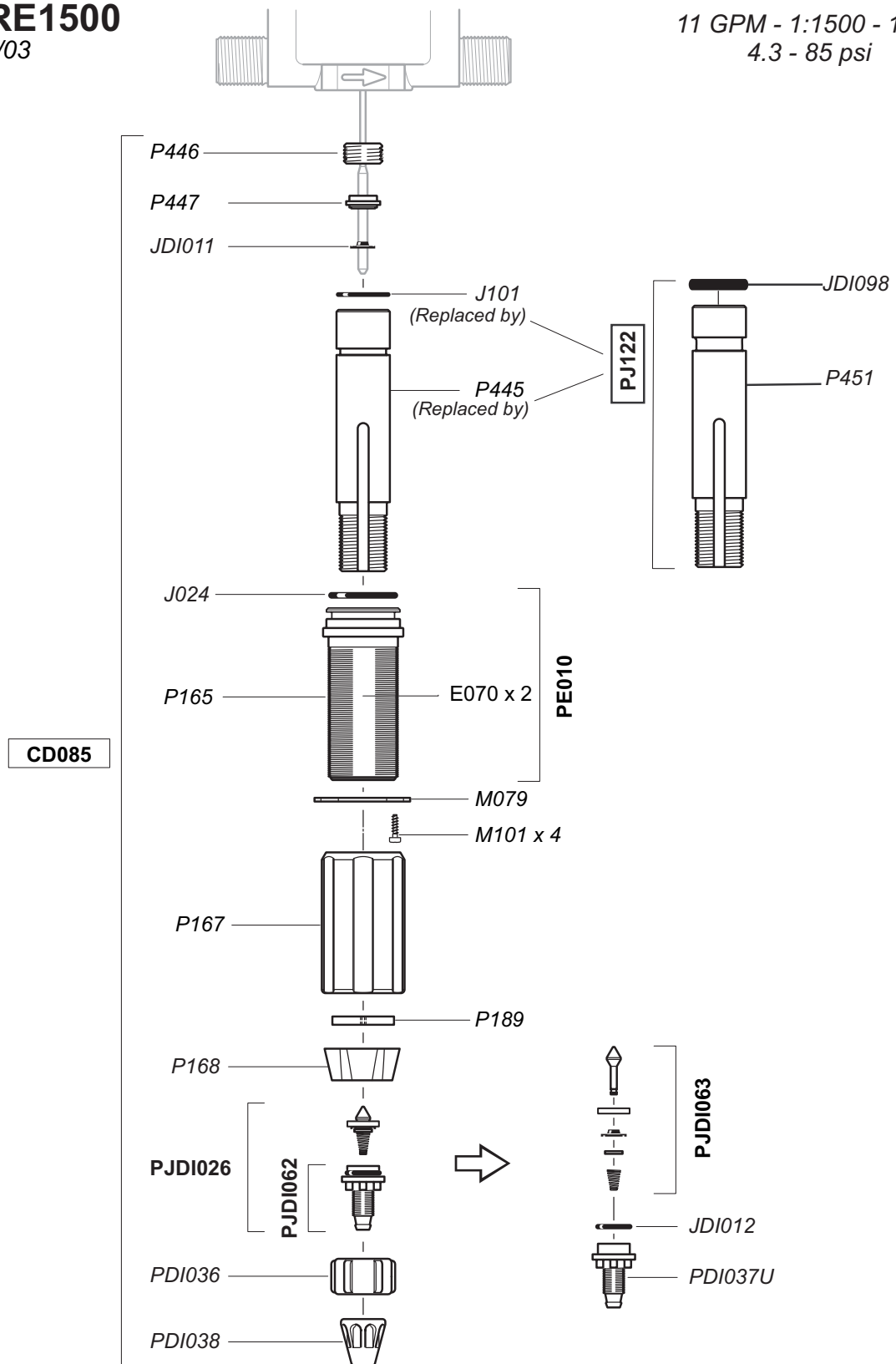

D25RE1500
11/03

11 GPM - 1:1500 - 1:500
4.3 - 85 psi

